

# Technical Data Sheet

## T303 - Tub, 565/110 MTE

### PRODUCT DIMENSIONS (mm)

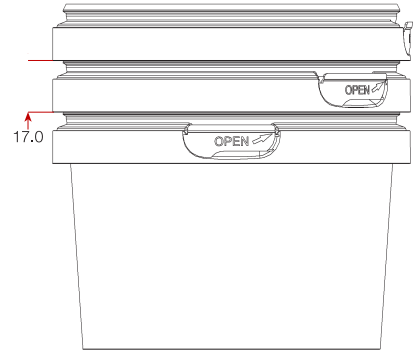
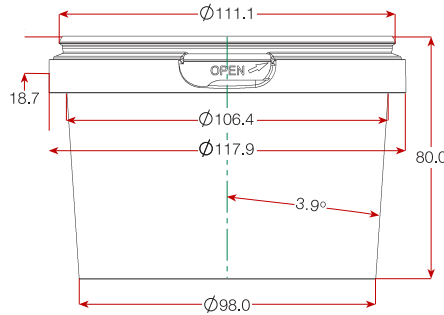
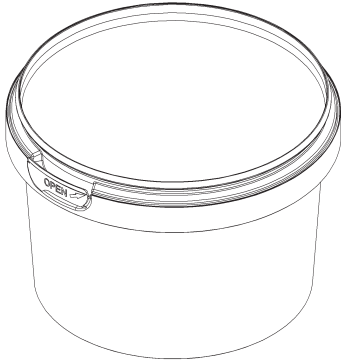

<b>SHAPE</b>	Round Conical		
<b>LID OPTIONS</b>	<b>Lid</b> L304 - 110 mm Snap On L309 - 110 mm Overlid	<b>Closure type</b> Plug-fit Overlid	<b>Seal integrity</b> Medium integrity Overlid
<b>VOLUME (typical values)</b>	Brimfull Underlid L304 Underlid L309	644 ml 570 ml 644 ml	without any headspace without any headspace without any headspace

<b>TAMPER EVIDENCE</b>	Tamper evidence break-out tab.	
<b>HANDLE</b>	Not available	
<b>HEIGHT (typical values)</b>	With lid L304 With lid L309	80.7 mm 82.6 mm
<b>WEIGHT (typical values)</b>	Tub Lid L304 Lid L309	20.4 g 8.9 g 8.3 g

<b>PACKING</b>	No. per carton Carton size Carton weight when full Carton liner Stack sleeve	340 600 mm L x 485 mm W x 370 mm H (0.108 m <sup>3</sup> ) 7.5 kg +/- kg Polypropylene (blue) Polypropylene.		
	<b>Pallet Specifications</b> Cartons per pallet Quantity per pallet Pallet dimensions Height including pallet Cubic metres (incl. pallet)	<b>Export</b> 20 6,800 1000 mm x 1200 mm 2.00 m 2.40 m <sup>3</sup>	<b>South Island</b> 20 6,800 1100 mm x 1060 mm 2.00 m 2.33 m <sup>3</sup>	<b>North Island</b> 12 4,080 1100 mm x 1060 mm 1.26 m 1.47 m <sup>3</sup>

<b>RAW MATERIAL</b>	PP (polypropylene) All of Tecpak's products are made from plastic polymers in grades that are suitable for food packaging and comply with US regulations FDA Title21, CFR Part 177 1520 for Olefin Polymers and/or EU Directive 2002/72/EEL.
---------------------	---

<b>ENVIRONMENTAL</b>	The material used in this product is recyclable. Local authorities should be contacted for information on curbside collection.
----------------------	--

<b>COLOURS</b>	Natural, Clear, White. Other colours available on request.
----------------	--

<b>DECORATION OPTIONS</b>	Dry offset printing ( <i>see separate printing specifications for this product</i> ). In Mould Labelling ( <i>see separate IML specifications for this product</i> ).
---------------------------	--

<b>QUALITY</b>	Tecpak Industries Limited is certified to ISO9001:2000.
----------------	---

<b>FOOD SAFETY</b>	Tecpak Industries Limited is certified to ISO22000:2005 Food Safety Management Systems.
--------------------	---

<b>PERFORMANCE</b>	<p><b>Hot Filling</b> The maximum fill temperature is 85°-95° C. Internal process trials should be undertaken to determine the viability of this product for the intended use.</p> <p><b>Freezing</b> The standard resin used for natural, white and coloured products will resist temperatures down to -20°C. Deep freezing below this temperature may require a special resin available on request. The standard resin used for clear products may become brittle at temperatures below 0° C. Internal process trials should be undertaken to determine the viability of this product for the intended use.</p> <p><b>Re-heating</b> This product may be microwaved. Internal process trials should be undertaken to determine the viability of this product for the intended use.</p> <p><b>Shelf Life</b> The compliance of the product to the technical specifications in this data sheet is guaranteed for 12 months after the date of delivery subject to suitable storage.</p> <p><b>Stacking (empty).</b> Ideally pallets should be stacked no more than two high. <b>Stacking (full).</b> It is recommended that this product be packed into self supporting trays or cardboard boxes. Internal process trials should be undertaken to determine the viability of free-standing stacking and transportation.</p> <p><b>Other</b> Resins used are dishwasher safe and are designed for re-usability.</p> <p><b>In all cases internal trials should be undertaken to determine the suitability of the packaging through all stages of the process.</b></p>
--------------------	--