

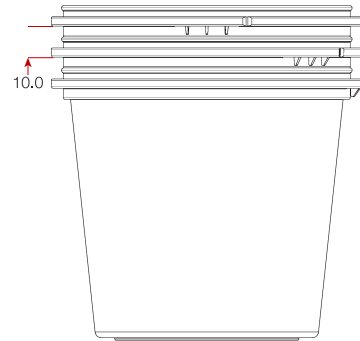

PRODUCT DIMENSIONS (mm)

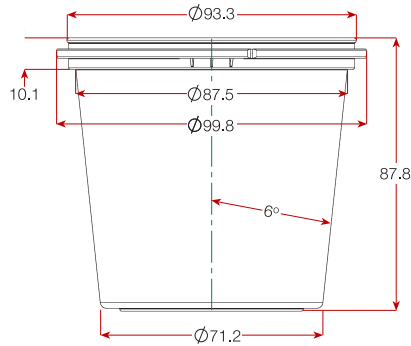

SHAPE	Round Conical			TAMPER EVIDENCE	Tamper evidence break-out tab.		
LID OPTIONS	Lid	Closure type	Seal integrity	HANDLE	Not available		
	L002 - 93 mm SAP	Plug-fit	High integrity	HEIGHT (typical values)	With lid L002	89.4 mm	
	L036 - 93 mm SL	Plug-fit	Medium integrity		With lid L036	88.3 mm	
	L098 - 93 mm Overlid	Overlid	Overlid		With lid L098	91.5 mm	
	L130 - 93 mm ROL	Overlid (raised)	Overlid		With lid L130	94.4 mm	
VOLUME (typical values)	Brimfull	415 ml	without any headspace	WEIGHT (typical values)	Tub	20.3 g	
	Underlid L002	388 ml	without any headspace		Lid L002	8.2 g	
	Underlid L036	383 ml	without any headspace		Lid L036	4.3 g	
	Underlid L098	415 ml	without any headspace		Lid L098	4.3 g	
	Underlid L130	415 ml	without any headspace		Lid L130	5.4 g	
PACKING	No. per carton	500		South Island	North Island		
	Carton size	510 mm L x 415 mm W x 350 mm H (0.074 m ³)		30	18		
	Carton weight when full	10.5 kg +/- kg		15,000	9,000		
	Carton liner	Polypropylene (blue)		1100 mm x 1300 mm	1100 mm x 1300 mm		
	Stack sleeve	Polypropylene.		1.90 m	1.20m		
	Pallet Specifications	Export		2.72 m ³	1.72 m ³		
	Cartons per pallet	24					
	Quantity per pallet	12,000					
	Pallet dimensions	1000 mm x 1200 mm					
	Height including pallet	2.25 m					
	Cubic metres (incl. pallet)	2.70 m ³					
RAW MATERIAL		PP (polypropylene) All of Tecpak's products are made from plastic polymers in grades that are suitable for food packaging and comply with US regulations FDA Title21, CFR Part 177 1520 for Olefin Polymers and/or EU Directive 2002/72/EEL.					
ENVIRONMENTAL	The material used in this product is recyclable. Local authorities should be contacted for information on curbside collection.						
COLOURS	Natural, Clear, White. Other colours available on request.						
DECORATION OPTIONS	Dry offset printing (<i>see separate printing specifications for this product</i>).						
QUALITY	Tecpak Industries Limited is certified to ISO9001:2000.						
FOOD SAFETY	Tecpak Industries Limited is certified to ISO22000:2005 Food Safety Management Systems.						
PERFORMANCE	<p>Hot Filling The maximum fill temperature is 85°-95° C. Internal process trials should be undertaken to determine the viability of this product for the intended use.</p> <p>Freezing The standard resin used for natural, white and coloured products will resist temperatures down to -20°C. Deep freezing below this temperature may require a special resin available on request. The standard resin used for clear products may become brittle at temperatures below 0° C. Internal process trials should be undertaken to determine the viability of this product for the intended use.</p> <p>Re-heating This product may be microwaved. Internal process trials should be undertaken to determine the viability of this product for the intended use.</p> <p>Shelf Life The compliance of the product to the technical specifications in this data sheet is guaranteed for 12 months after the date of delivery subject to suitable storage.</p> <p>Stacking (empty). Ideally pallets should be stacked no more than two high. Stacking (full). It is recommended that this product be packed into self supporting trays or cardboard boxes. Internal process trials should be undertaken to determine the viability of free-standing stacking and transportation.</p> <p>Other Resins used are dishwasher safe and are designed for re-usability.</p> <p>In all cases internal trials should be undertaken to determine the suitability of the packaging through all stages of the process.</p>						