

Technical Data Sheet

T301 - Tub, 365/86 MTE

PRODUCT DIMENSIONS (mm)

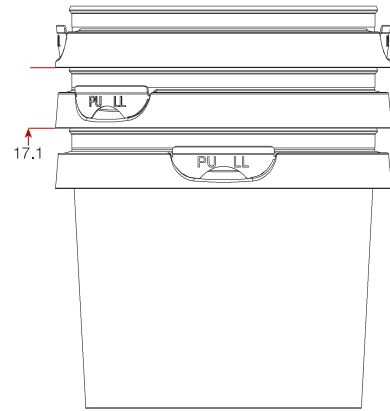
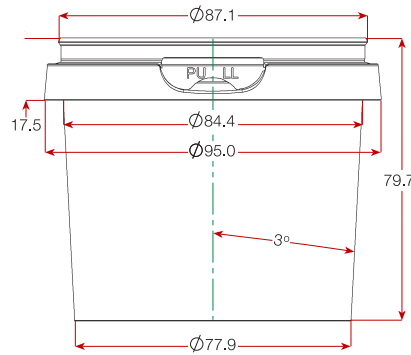
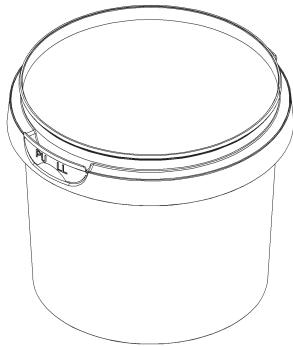

SHAPE	Round Conical			TAMPER EVIDENCE	Tamper evidence break-out tab.		
LID OPTIONS	Lid L310 - 86 mm Snap On L323 - 86 mm Overlid	Closure type Plug-fit Overlid	Seal integrity Medium integrity Overlid	HANDLE	Not available		
VOLUME (typical values)	Brimfull Underlid L310 Underlid L323	404 ml 366 ml 404 ml	without any headspace without any headspace without any headspace	HEIGHT (typical values)	With lid L310 With lid L323	80.3 mm 82.7 mm	
PACKING	No. per carton Carton size Carton weight when full Carton liner Stack sleeve Pallet Specifications Cartons per pallet Quantity per pallet Pallet dimensions Height including pallet Cubic metres (incl. pallet)	600 515 mm L x 515 mm W x 505 mm H (0.134 m ³) 9.5 kg +/- kg Polypropylene (blue) Polypropylene.		WEIGHT (typical values)	Tub Lid L310 Lid L323	13.9 g 5.8 g 5.1 g	
RAW MATERIAL	PP (polypropylene) All of Tecpak's products are made from plastic polymers in grades that are suitable for food packaging and comply with US regulations FDA Title21, CFR Part 177 1520 for Olefin Polymers and/or EU Directive 2002/72/EEL.			Export	South Island	North Island	
ENVIRONMENTAL	The material used in this product is recyclable. Local authorities should be contacted for information on curbside collection.						
COLOURS	Natural, Clear, White. Other colours available on request.						
DECORATION OPTIONS	Dry offset printing (<i>see separate printing specifications for this product</i>). In Mould Labelling (<i>see separate IML specifications for this product</i>).						
QUALITY	Tecpak Industries Limited is certified to ISO9001:2000.						
FOOD SAFETY	Tecpak Industries Limited is certified to ISO22000:2005 Food Safety Management Systems.						
PERFORMANCE	<p>Hot Filling The maximum fill temperature is 85°-95° C. Internal process trials should be undertaken to determine the viability of this product for the intended use.</p> <p>Freezing The standard resin used for natural, white and coloured products will resist temperatures down to -20°C. Deep freezing below this temperature may require a special resin available on request. The standard resin used for clear products may become brittle at temperatures below 0° C. Internal process trials should be undertaken to determine the viability of this product for the intended use.</p> <p>Re-heating This product may be microwaved. Internal process trials should be undertaken to determine the viability of this product for the intended use.</p> <p>Shelf Life The compliance of the product to the technical specifications in this data sheet is guaranteed for 12 months after the date of delivery subject to suitable storage.</p> <p>Stacking (empty). Ideally pallets should be stacked no more than two high. Stacking (full). It is recommended that this product be packed into self supporting trays or cardboard boxes. Internal process trials should be undertaken to determine the viability of free-standing stacking and transportation.</p> <p>Other Resins used are dishwasher safe and are designed for re-usability.</p> <p>In all cases internal trials should be undertaken to determine the suitability of the packaging through all stages of the process.</p>						