

PRODUCT DIMENSIONS (mm)

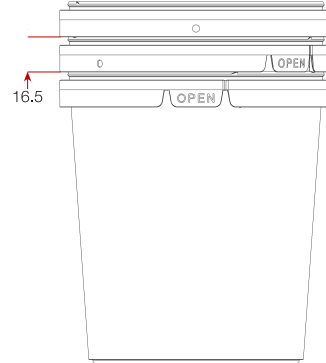
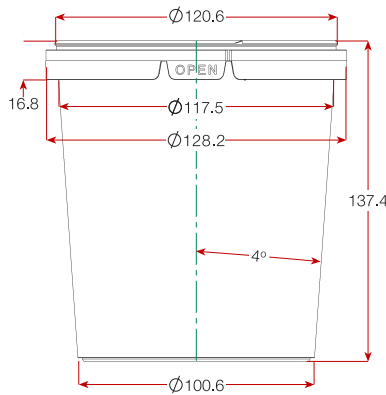

SHAPE	Round Conical			TAMPER EVIDENCE	Tamper evidence break-out tab.	
LID OPTIONS	Lid L139 - 120 mm Snap On	Closure type Plug-fit	Seal integrity Medium integrity	HANDLE	Available	
VOLUME (typical values)	Brimfull	1,261 ml	without any headspace	HEIGHT (typical values)	With lid L139	138.0 mm
	Underlid L139	1,200 ml	without any headspace	WEIGHT (typical values)	Tub	47.8 g
					Lid L139	10.0 g
PACKING	No. per carton	300				
	Carton size	535 mm L x 445 mm W x 555 mm H (0.132 m ³)				
	Carton weight when full	14.5 kg +/- kg				
	Carton liner	Polypropylene (blue)				
	Stack sleeve	Polypropylene.				
	Pallet Specifications	Export		South Island	North Island	
	Cartons per pallet	12		16	8	
	Quantity per pallet	3,600		4,800	2,400	
	Pallet dimensions	1000 mm x 1200 mm		1100 mm x 1060 mm	1100 mm x 1060 mm	
	Height including pallet	1.82 m		2.37 m	1.26 m	
	Cubic metres (incl. pallet)	2.18 m ³		2.76 m ³	1.47 m ³	
RAW MATERIAL	PP (polypropylene) All of Tecpak's products are made from plastic polymers in grades that are suitable for food packaging and comply with US regulations FDA Title21, CFR Part 177 1520 for Olefin Polymers and/or EU Directive 2002/72/EEL.					
ENVIRONMENTAL	The material used in this product is recyclable. Local authorities should be contacted for information on curbside collection.					
COLOURS	Natural, Clear, White. Other colours available on request.					
DECORATION OPTIONS	In Mould Labelling (<i>see separate IML specifications for this product</i>).					
QUALITY	Tecpak Industries Limited is certified to ISO9001:2000.					
FOOD SAFETY	Tecpak Industries Limited is certified to ISO22000:2005 Food Safety Management Systems.					
PERFORMANCE	Hot Filling The maximum fill temperature is 85°-95° C. Internal process trials should be undertaken to determine the viability of this product for the intended use. Freezing The standard resin used for natural, white and coloured products will resist temperatures down to -20°C. Deep freezing below this temperature may require a special resin available on request. The standard resin used for clear products may become brittle at temperatures below 0° C. Internal process trials should be undertaken to determine the viability of this product for the intended use. Re-heating This product may be microwaved. Internal process trials should be undertaken to determine the viability of this product for the intended use. Shelf Life The compliance of the product to the technical specifications in this data sheet is guaranteed for 12 months after the date of delivery subject to suitable storage. Stacking (empty). Ideally pallets should be stacked no more than two high. Stacking (full). It is recommended that this product be packed into self supporting trays or cardboard boxes. Internal process trials should be undertaken to determine the viability of free-standing stacking and transportation. Other Resins used are dishwasher safe and are designed for re-usability. In all cases internal trials should be undertaken to determine the suitability of the packaging through all stages of the process.					