

# Technical Data Sheet

## T121 - Tub, 120/64 MTE

**PRODUCT DIMENSIONS (mm)**

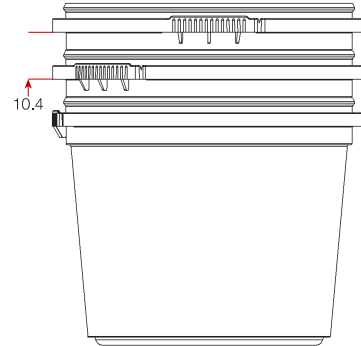
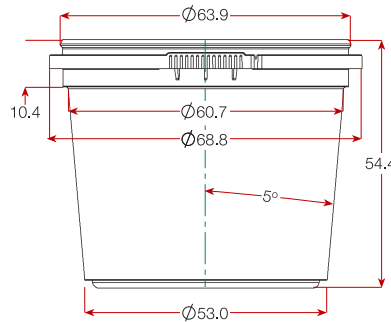
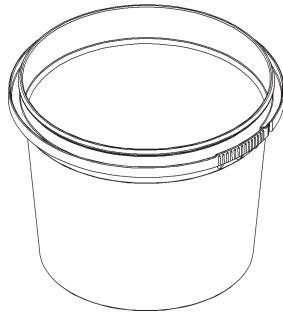

<b>SHAPE</b>	Round Conical		
<b>LID OPTIONS</b>	<b>Lid</b> L125 - 64 mm Snap On L126 - 64 mm Overlid	<b>Closure type</b> Plug-fit Overlid	<b>Seal integrity</b> Medium integrity Overlid
<b>VOLUME (typical values)</b>	Brimfull Underlid L125 Underlid L126	135 ml 118 ml 135 ml	without any headspace without any headspace without any headspace

<b>TAMPER EVIDENCE</b>	Tamper evidence break-out tab.	
<b>HANDLE</b>	Not available	
<b>HEIGHT (typical values)</b>	With lid L125 With lid L126	54.8 mm 57.4 mm
<b>WEIGHT (typical values)</b>	Tub Lid L125 Lid L126	7.1 g 2.2 g 2.2 g

<b>PACKING</b>	No. per carton Carton size Carton weight when full Carton liner Stack sleeve	1600 495 mm L x 495 mm W x 405 mm H (0.099 m <sup>3</sup> ) 12.0 kg +/- kg Polypropylene (blue) Polypropylene.		
	<b>Pallet Specifications</b>	<b>Export</b>	<b>South Island</b>	<b>North Island</b>
	Cartons per pallet Quantity per pallet Pallet dimensions Height including pallet Cubic metres (incl. pallet)	20 32,000 1000 mm x 1200 mm 2.18 m 2.61 m <sup>3</sup>	20 32,000 1100 mm x 1060 mm 2.18 m 2.54 m <sup>3</sup>	12 19,200 1100 mm x 1060 mm 1.37 m 1.59 m <sup>3</sup>

<b>RAW MATERIAL</b>	PP (polypropylene) All of Tecpak's products are made from plastic polymers in grades that are suitable for food packaging and comply with US regulations FDA Title21, CFR Part 177 1520 for Olefin Polymers and/or EU Directive 2002/72/EEL.
---------------------	---

<b>ENVIRONMENTAL</b>	The material used in this product is recyclable. Local authorities should be contacted for information on curbside collection.
----------------------	--

<b>COLOURS</b>	Natural, Clear, White. Other colours available on request.
----------------	--

<b>DECORATION OPTIONS</b>	Dry offset printing ( <i>see separate printing specifications for this product</i> ).
---------------------------	---

<b>QUALITY</b>	Tecpak Industries Limited is certified to ISO9001:2000.
----------------	---

<b>FOOD SAFETY</b>	Tecpak Industries Limited is certified to ISO22000:2005 Food Safety Management Systems.
--------------------	---

<b>PERFORMANCE</b>	<p><b>Hot Filling</b> The maximum fill temperature is 85°-95° C. Internal process trials should be undertaken to determine the viability of this product for the intended use.</p> <p><b>Freezing</b> The standard resin used for natural, white and coloured products will resist temperatures down to -20°C. Deep freezing below this temperature may require a special resin available on request. The standard resin used for clear products may become brittle at temperatures below 0° C. Internal process trials should be undertaken to determine the viability of this product for the intended use.</p> <p><b>Re-heating</b> This product may be microwaved. Internal process trials should be undertaken to determine the viability of this product for the intended use.</p> <p><b>Shelf Life</b> The compliance of the product to the technical specifications in this data sheet is guaranteed for 12 months after the date of delivery subject to suitable storage.</p> <p><b>Stacking (empty).</b> Ideally pallets should be stacked no more than two high.  <b>Stacking (full).</b> It is recommended that this product be packed into self supporting trays or cardboard boxes. Internal process trials should be undertaken to determine the viability of free-standing stacking and transportation.</p> <p><b>Other</b> Resins used are dishwasher safe and are designed for re-usability.</p> <p><b>In all cases internal trials should be undertaken to determine the suitability of the packaging through all stages of the process.</b></p>
--------------------	---